

Centre for Mechanics of Liquid
The Szewalski Institute of Fluid Flow Machinery
of the Polish Academy of Sciences



Kaplan turbine numerical simulations

Zbigniew Krzemianowski, Maciej Kaniecki,
Marzena Banaszek

The plan of presentation

- 1. Cam-curve determination for bulb-turbine using CFD simulations.**
- 2. Comparison of numerical and experimental data for model test turbine.**

Example 1

Cam-curve determination for bulb-turbine
using CFD simulations.

Draft of bulb-turbine physical model

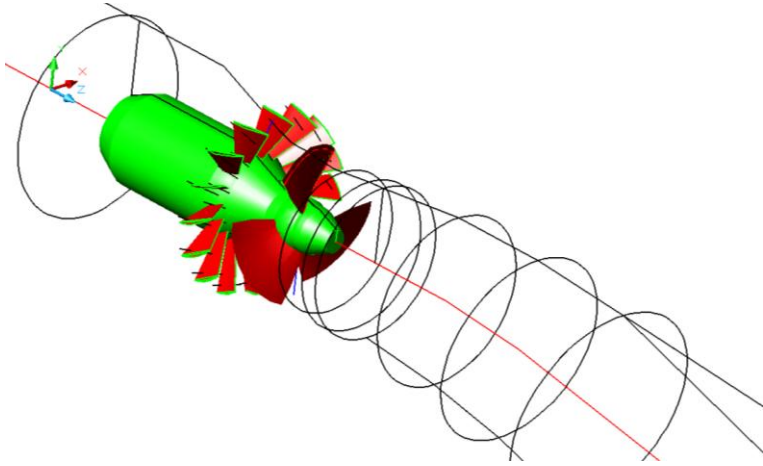

A view of flow system of bulb-turbine

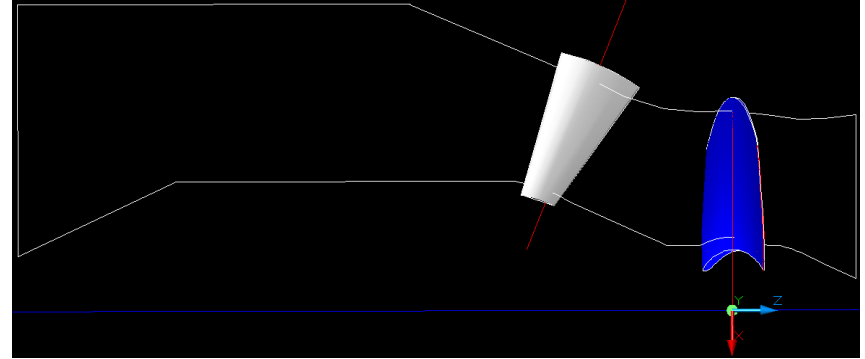

Meridional view of blade channel

Net Head H_{net} [m]	3.0
Rotational speed [rpm]	305
Rotor diameter D [m]	1.09
Number of runner blades	3
Number of guide vanes	16

Geometrical and operating parameters of the examined turbine

Determination of optimal cam-curve head $H_{h\dot{s}r} = 4.41$ m

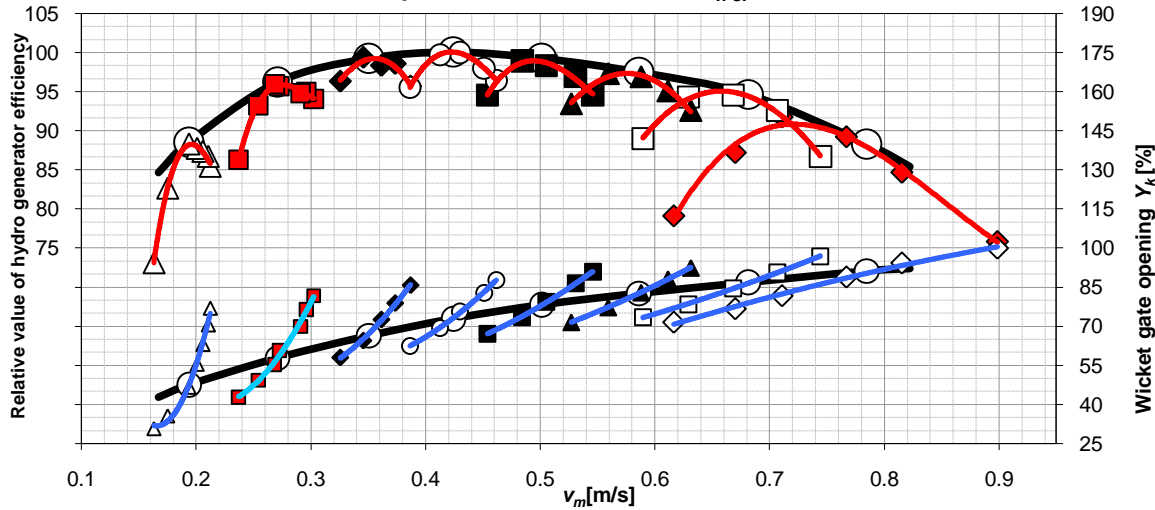

Installation of the current meters for cam-curve determination

Exemplary propeller curves diagram

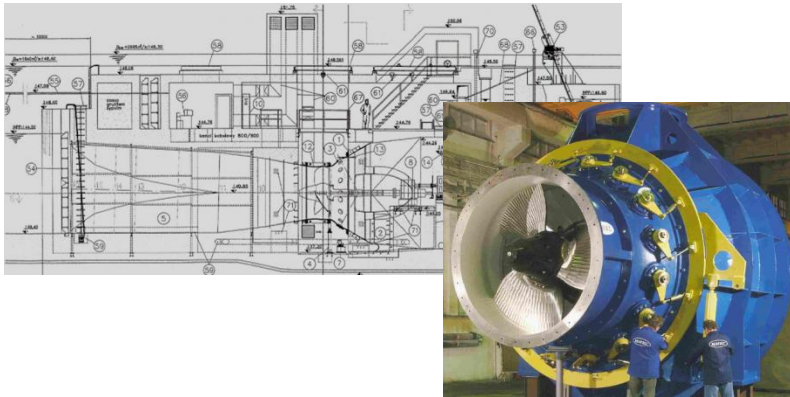

Bulb turbine for Small Hydro of MAVEL production

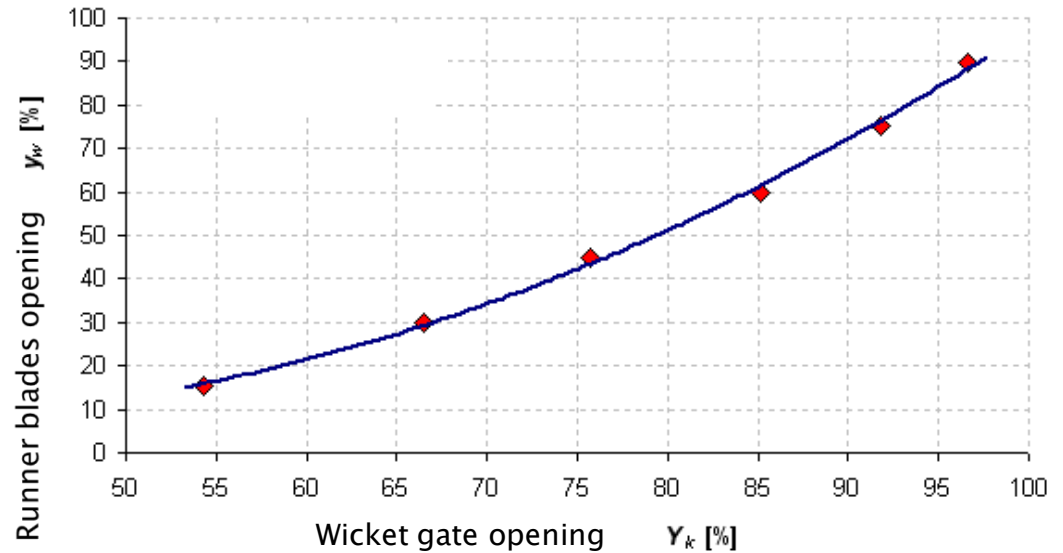

Exemplary cam-curve relation

Numerical model

Grid parameters:

- hexahedral elements,
- ~7.2 mln nodes.
- Y^+ : 1-3.

Numerical calculations

- steady state flow,
- turbulent model: k- ϵ RNG,
- computation time ~30 hours for 10 000 iterations.

Boundary conditions:

- total pressure at the inlet: 31000 Pa (3.161 m),
- static pressure at the outlet: 0 Pa,
- rotational speed: 270 rpm – 325 rpm.

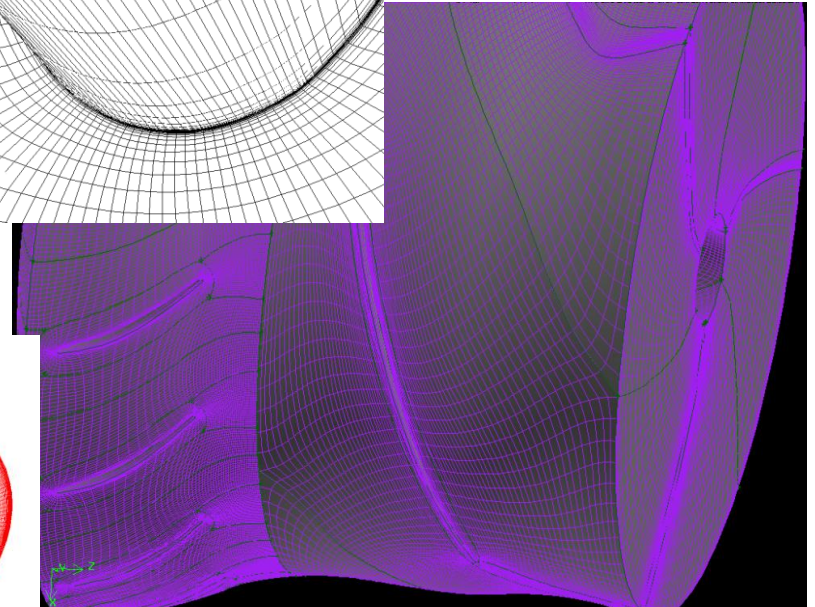
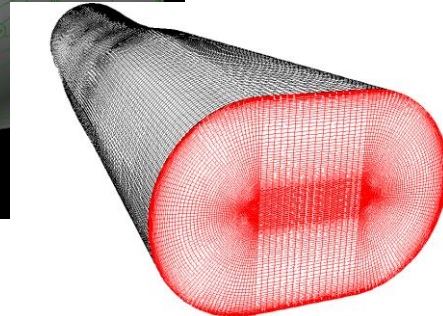
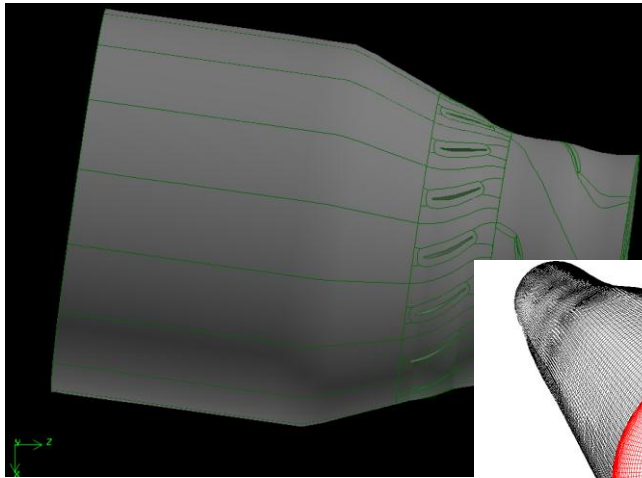
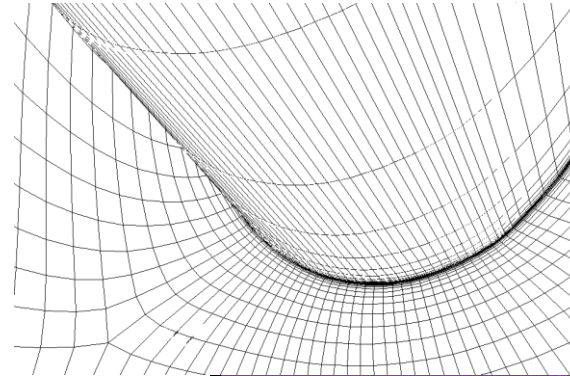
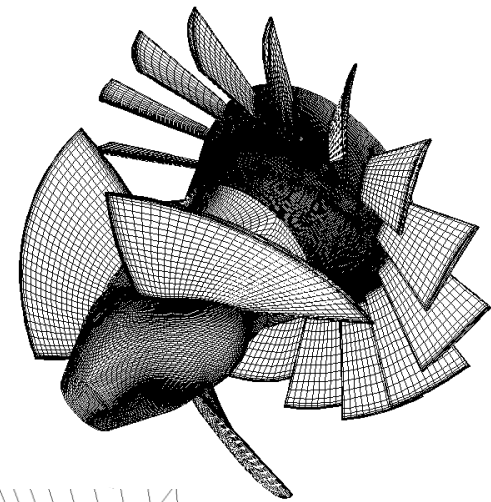

The results of numerical determination of cam-curve

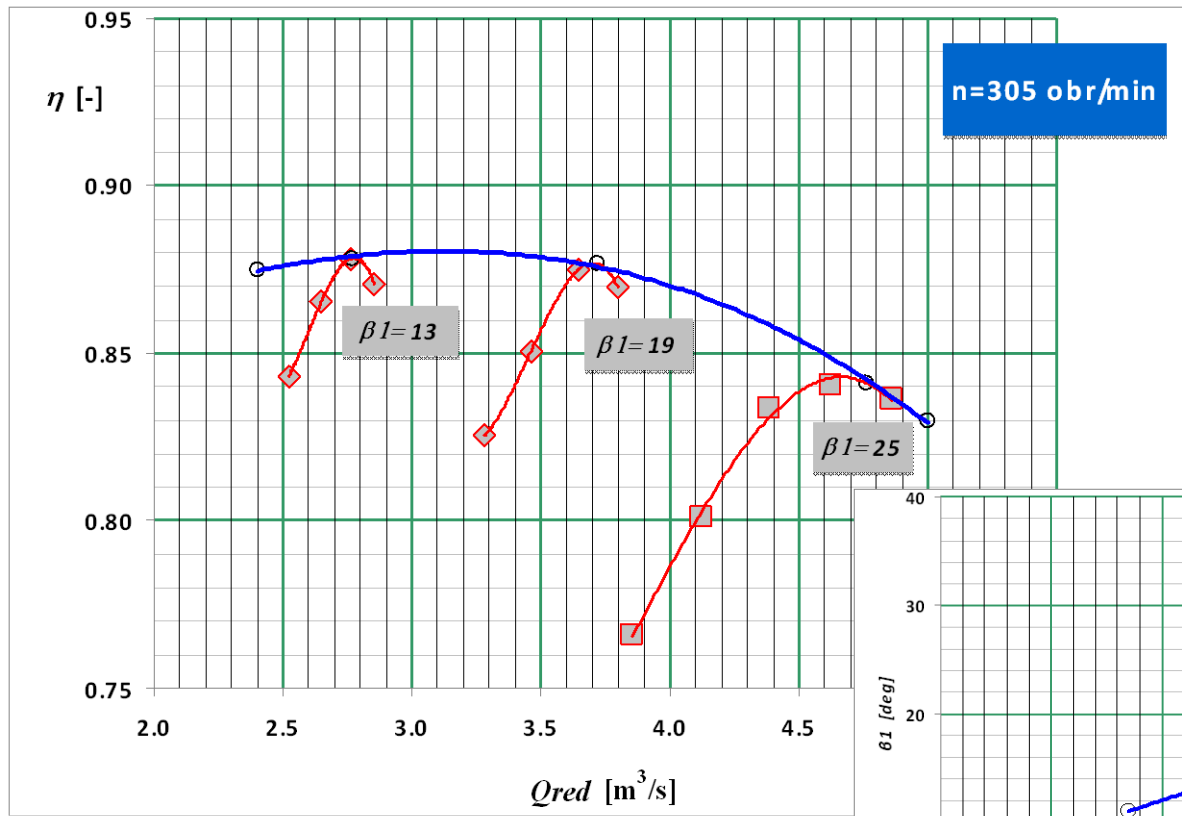

Propeller curves diagram for rotational speed $n=305\text{rpm}$.

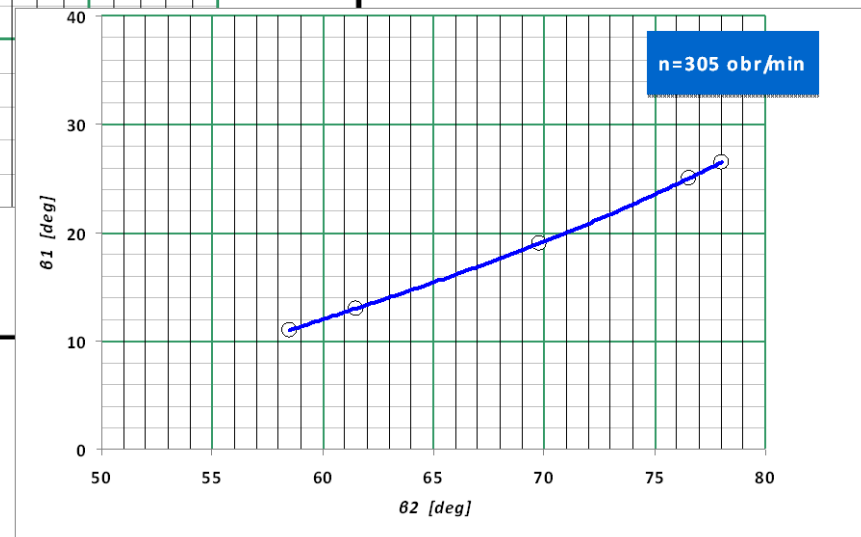

Cam-curve for rotational speed $n=305\text{rpm}$.

The numerical result of CFD flow analysis

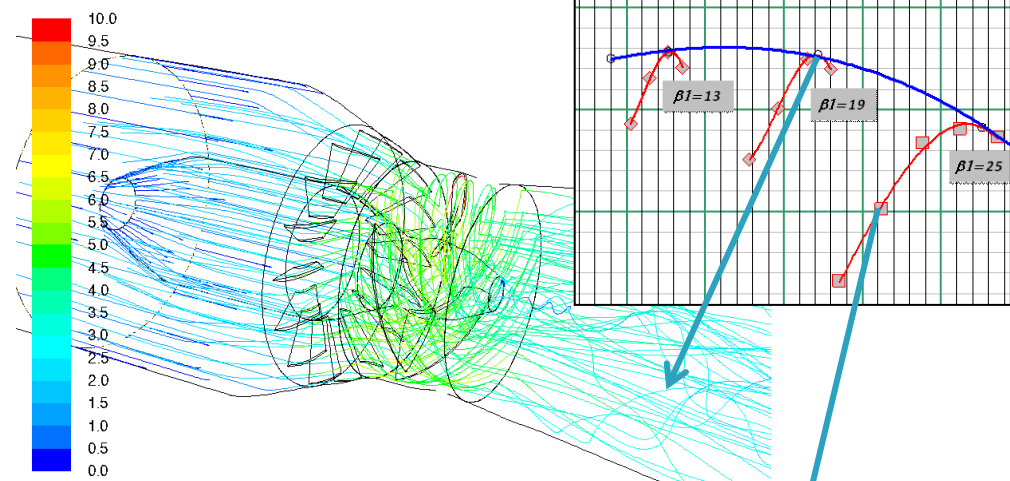
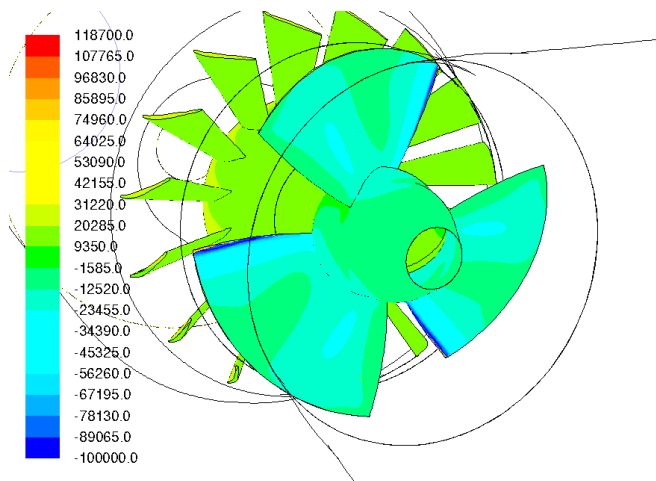

Distribution of the static pressure and streamlines for optimal operating point W19K67 $n=305$ rpm.

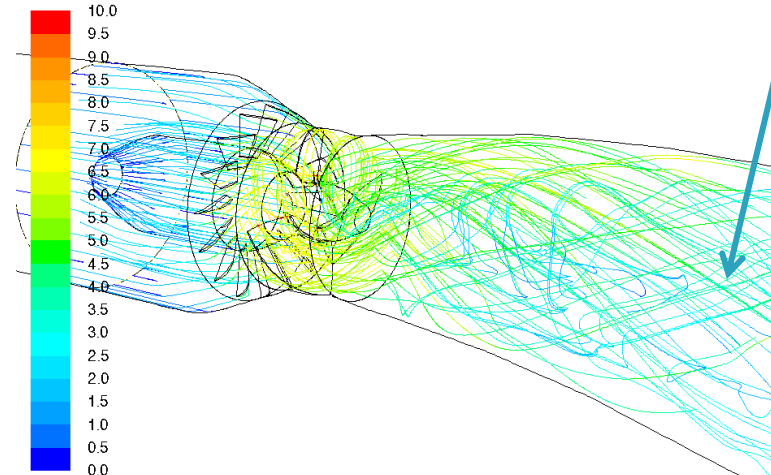
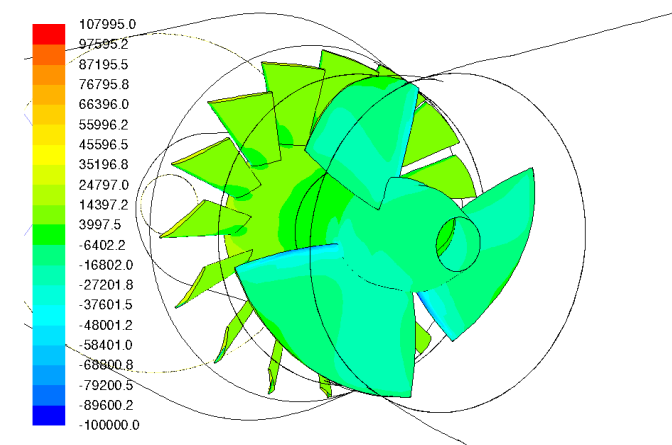

Distribution of the static pressure and streamlines for low value efficiency point W25K55 $n=305$ rpm.

Exemple 2

Comparison of numerical and experimental data for model test turbine.

Physical and numerical model

Geometry:

- vertical installation of the turbine
- the number of stay vanes – 6,
- the number of guide vanes – 12,
- the number of runner blades – 6,
- Diameter of the runner $D=0.265$ m.

Grid parameters

- hexahedral elements,
- ~7.1 mln nodes,
- Y^+ : 1-3.

Numerical calculations

- stationary,
- turbulent models: k-e RNG, kw SST ...
- computation time ~60 hours for 20 000 iterations.

Boundary conditions:

- total pressure at the inlet: 26726 Pa (2.725 m),
- static pressure at the outlet : 0 Pa,
- rotational speed: 650 rpm.

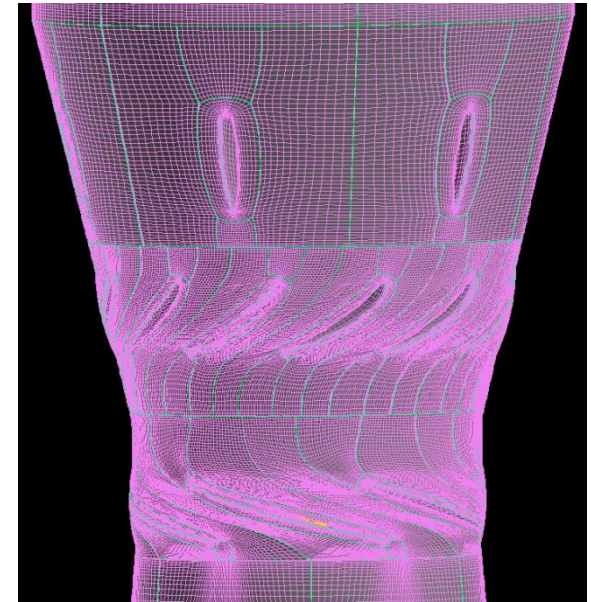
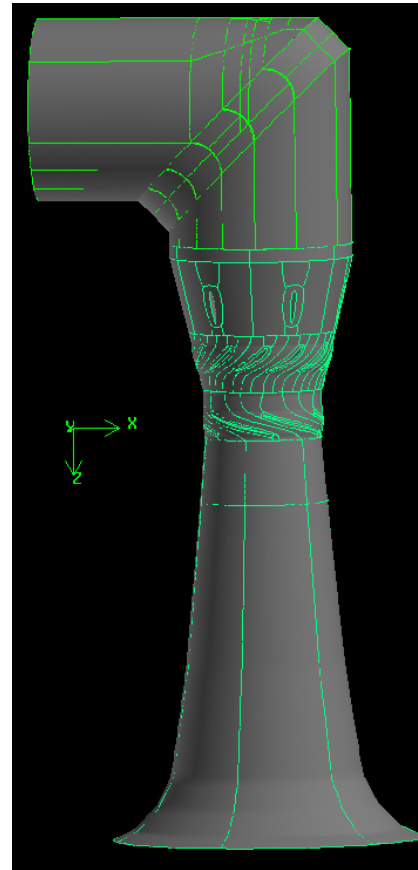
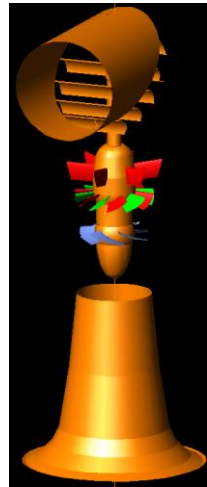

Numerical test results

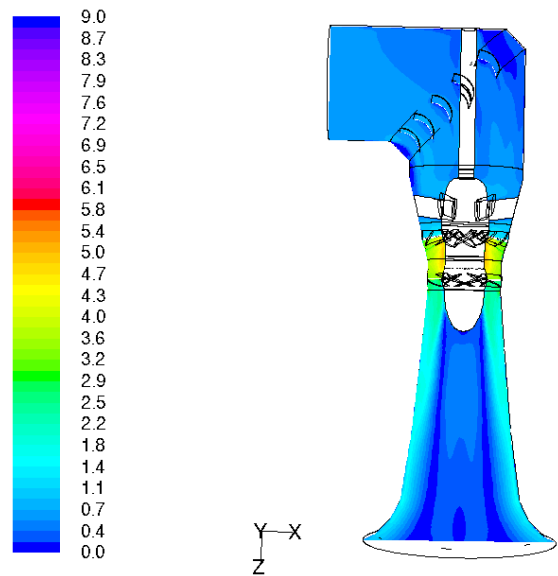

Contours of Velocity Magnitude (m/s) Dec 17, 2010
ANSYS FLUENT 12.1 (3d, dp, pbns, rngke)

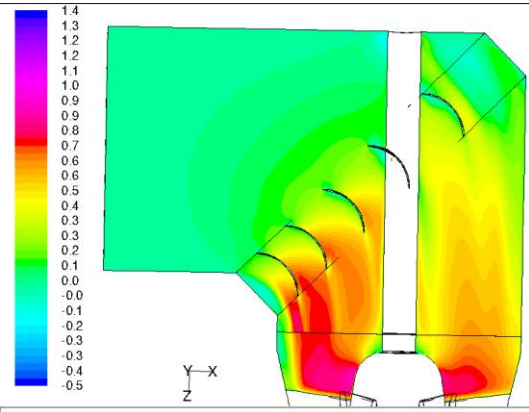

Contours of Z Velocity (m/s) Dec 17, 2010
ANSYS FLUENT 12.1 (3d, dp, pbns, rngke)

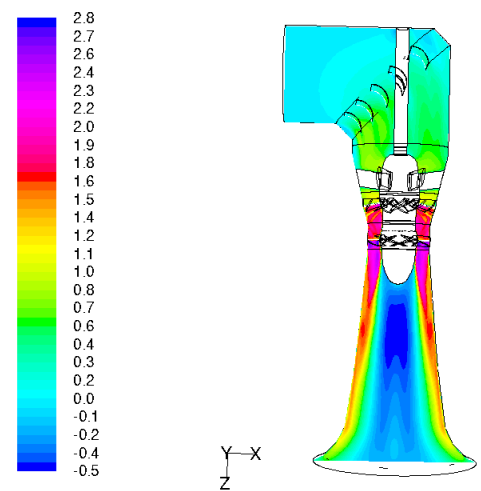

Contours of Z Velocity (m/s) Dec 17, 2010
ANSYS FLUENT 12.1 (3d, dp, pbns, rngke)

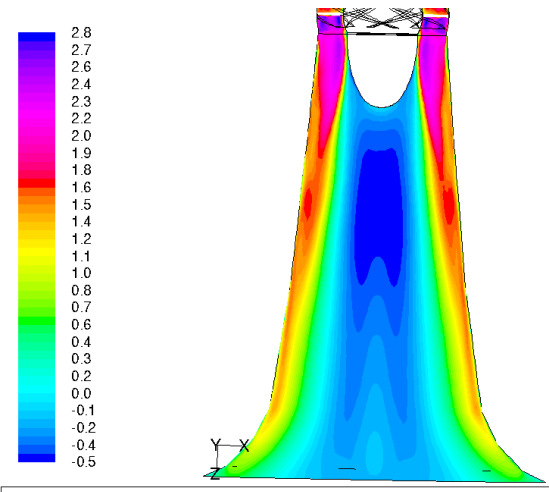

Contours of Z Velocity (m/s) Dec 17, 2010
ANSYS FLUENT 12.1 (3d, dp, pbns, rngke)

Numerical test results

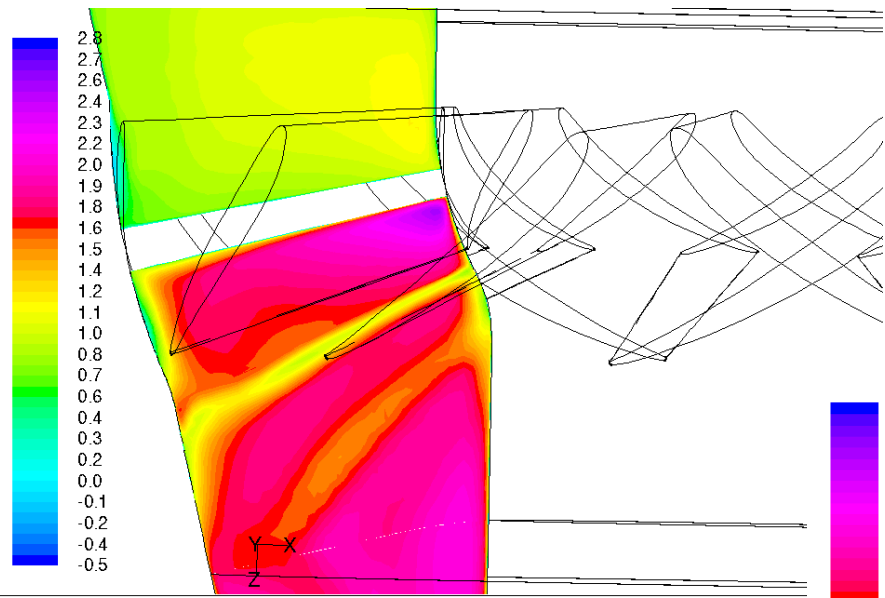

Contours of Z Velocity (m/s)

Dec 1:
ANSYS FLUENT 12.1 (3d, dp, pbns,

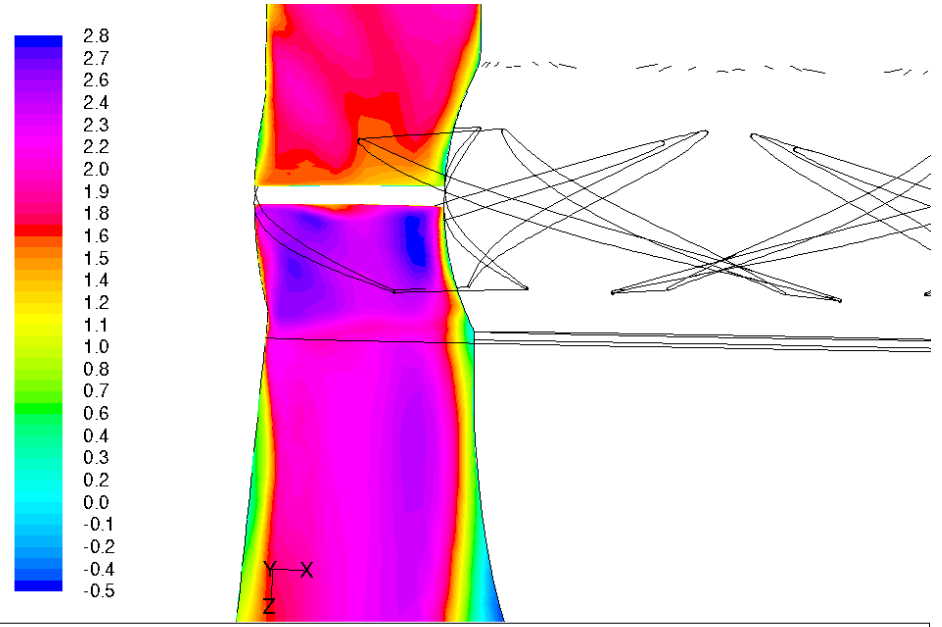

Contours of Z Velocity (m/s)

Dec 17, 2010
ANSYS FLUENT 12.1 (3d, dp, pbns, rngke)

Numerical test results

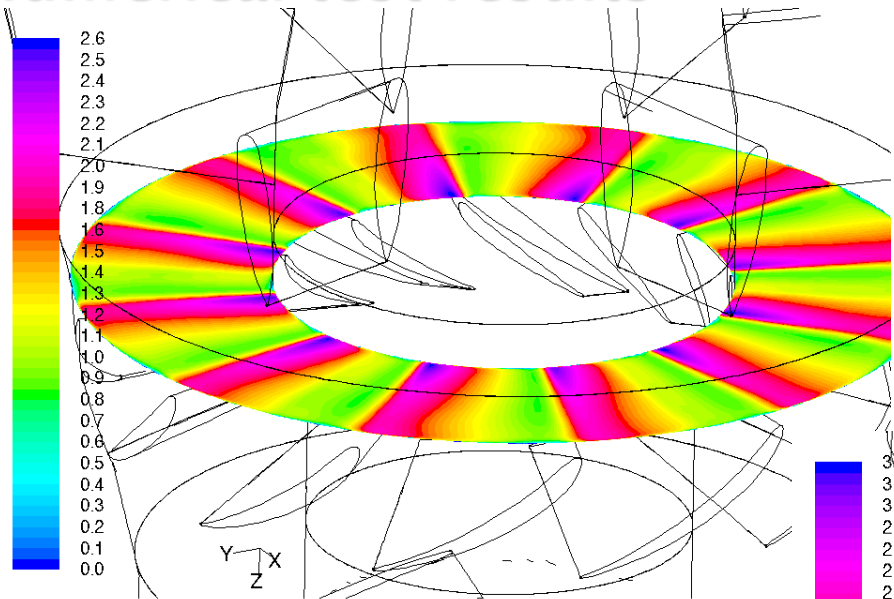

Contours of Velocity Magnitude (m/s) ANSYS FLUENT 12.1 (3d, dp, pbi) Dec

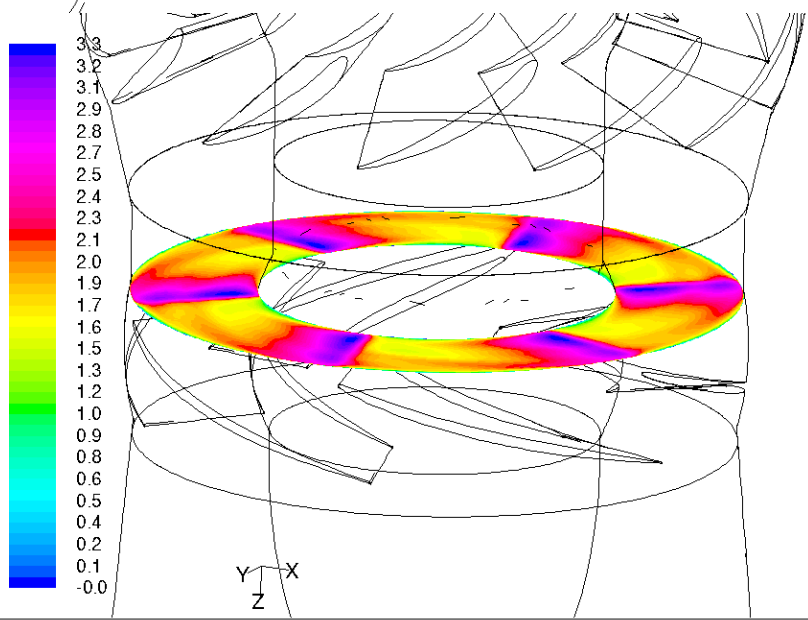

Contours of Z Velocity (m/s) ANSYS FLUENT 12.1 (3d, dp, pbns, rngke) Dec 17, 2010

Numerical test results

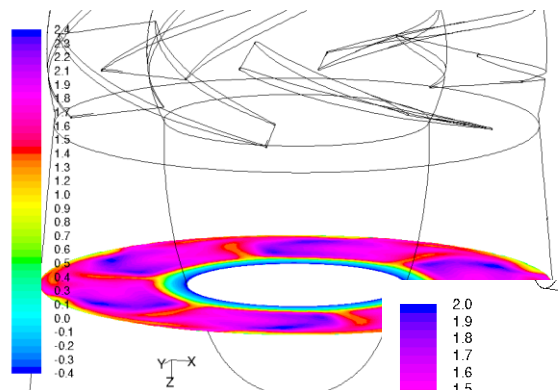

Contours of Z Velocity (m/s) ANSYS FL

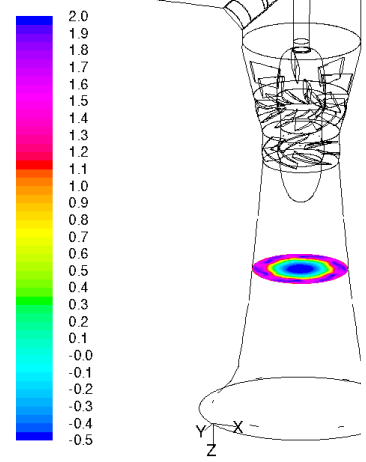

Contours of Z Velocity (m/s)

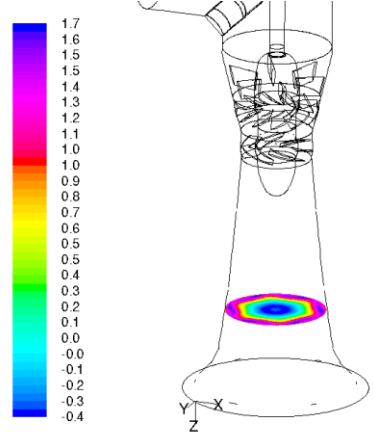

Contours of Z Velocity (m/s)

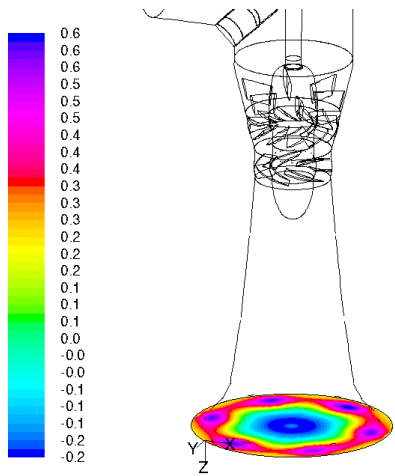

Contours of Z Velocity (m/s) ANSYS FLUENT 12.1 (3d, dp, pbns, rngke) Dec 17, 2010

Comparison between the experiment and numerical results for different turbulent models

Turbulence model	Torque	Power output	Mass flow rate	Efficiency	Efficiency relative difference (experiment vs. computations)
-	Nm	W	kg/s	-	%
Experiment	25.900	1763.0	74.302	0.8873 (± 0.015)	-
Spalart-Allmaras	25.709	1750.0	74.140	0.8848	0.28
k- ϵ RNG Standard WF	24.477	1666.1	74.080	0.8439	4.96
k- ϵ RNG Enhanced WF	25.156	1712.3	73.783	0.8715	1.78
k- ϵ RNG Non-Equilibrium	23.427	1594.6	74.172	0.8066	8.07
k- ϵ Realizable Standard	24.976	1700.1	74.215	0.8585	2.88
k- ϵ Realizable Enhanced	25.783	1755	74.201	0.8866	0.07
k- ω SST	25.780	1754.8	74.353	0.8851	0.25